

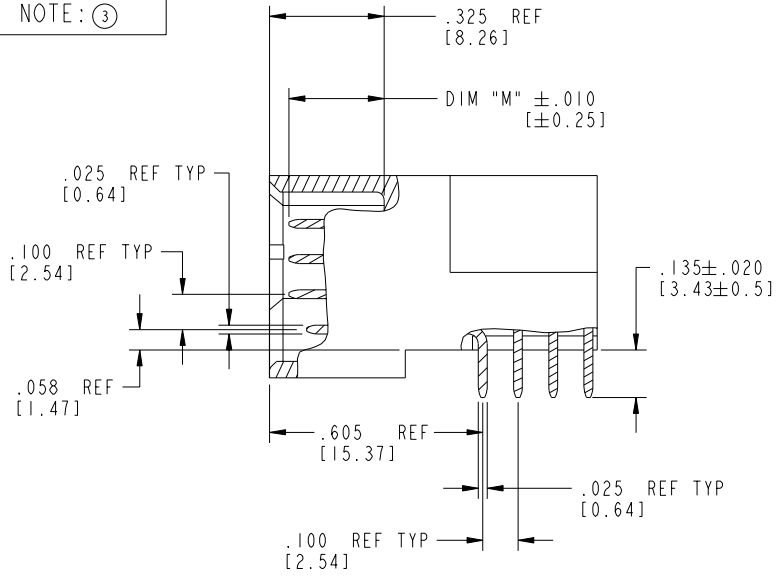

Tous droits strictement réservés. Reproduction ou communication a des tiers interdite sous quelque forme que ce soit sans autorisation écrite du propriétaire. Propriété de c FCI. Droits de reproduction FCI.

All rights strictly reserved. Reproduction or issue to third parties in any form whatever is not permitted without written authority from the proprietor. Property of FCI. Copyright FCI.

PRODUCT NUMBER  
51730-089--  
NOTE: ③



BROKEN-OUT SECTION A-A  
SCALE 2:1

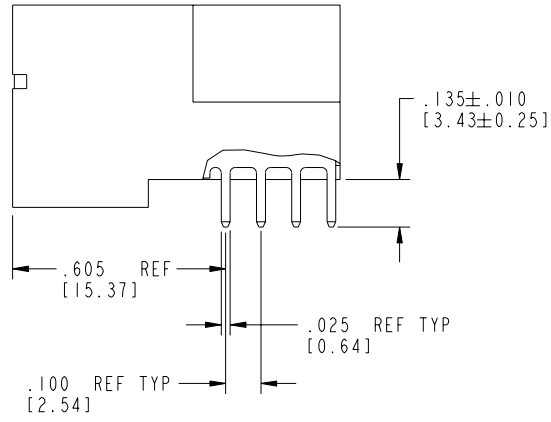

BROKEN-OUT SECTION B-B  
SCALE 2:1

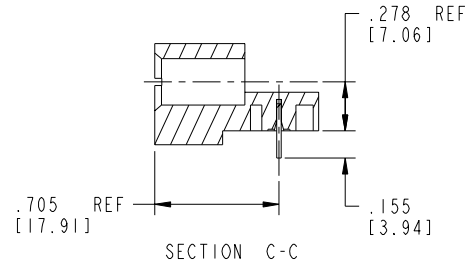

SECTION C-C

mat'l code		SEE NOTE 2		tolerances unless otherwise specified		CUSTOMER		 www.fciconnect.com	
lfr	ecn no.	dr	date	linear	.XX±.01/0.X±0.3	COPY		projection	title
c				angles	.XXX±.005/0.XX±0.13				4P + 40S + 4P
				dr	.XXX±.0020/0.XXX±0.051			product family	RIGHT ANGLE SOLDER HEADER
				enr	0°±2°			PwrBlade	code
				chr	D. INGRAM 02/10/04			size	213
				appd	M. GRAY 02/10/04			dwg no	sheet
					M. GRAY 02/10/04			51730-089	2 of 4
sheet index	revision sheet								

cage code 22526

Pro/E

PDM: Rev:C

STATUS:Released

Printed: Aug 12, 2007

Tous droits strictement réservés. Reproduction ou communication a des tiers interdite sous quelque forme que ce soit sans autorisation écrite du propriétaire. Propriété de c FCI. Droits de reproduction FCI.

All rights strictly reserved. Reproduction or issue to third parties in any form whatever is not permitted without written authority from the proprietor. Property of FCI. Copyright FCI.

PRODUCT NUMBER  
51730-089\_--  
NOTE: ③

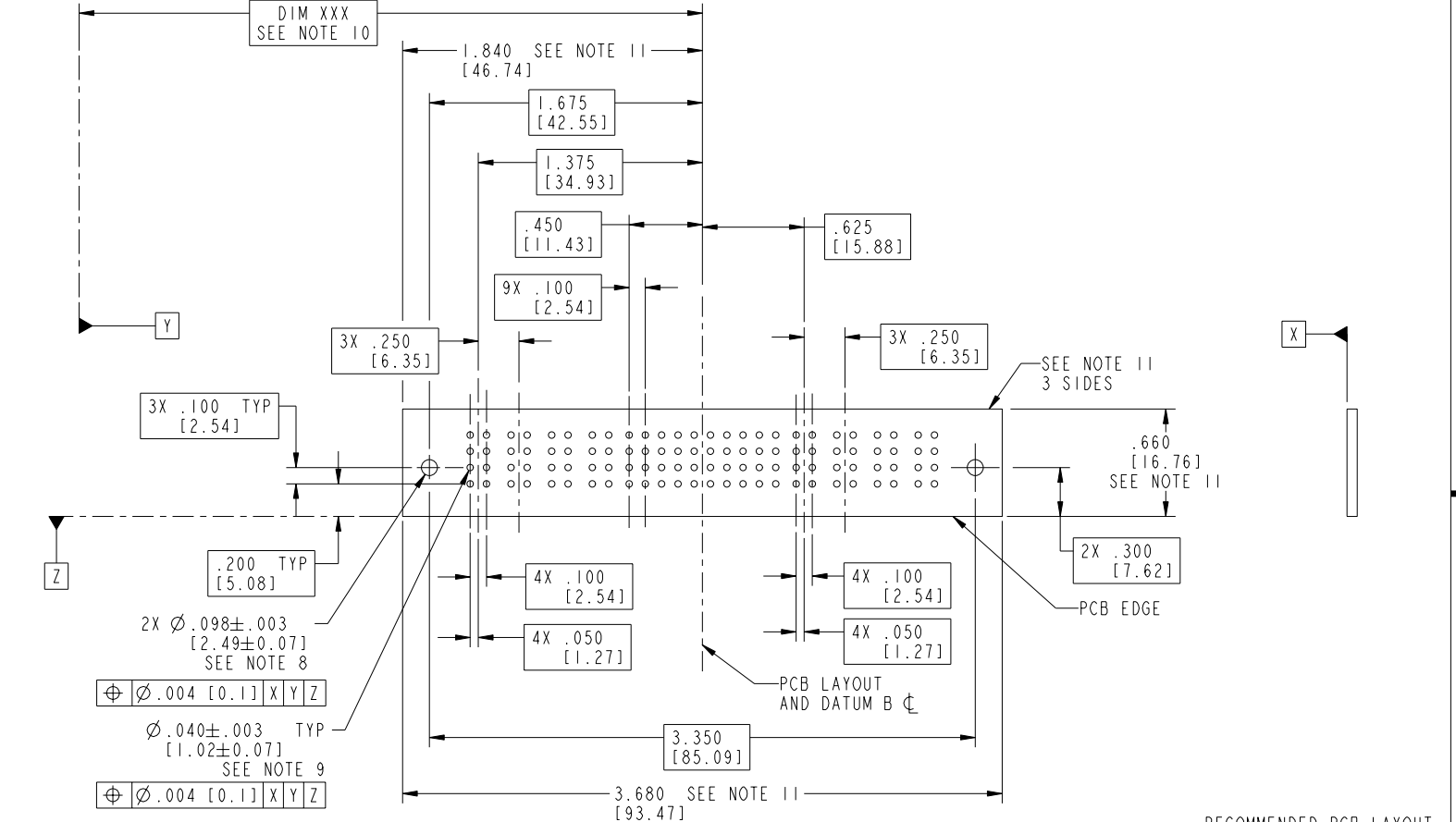

RECOMMENDED PCB LAYOUT

mat'l code SEE NOTE 2				tolerances unless otherwise specified		CUSTOMER		 www.fciconnect.com	
ltr	ecn no.	dr	date	linear	.XX±.01/0.X±0.3	COPY		title 4P + 40S + 4P	
C				angles	.XXX±.005/0.XX±0.13	projection		RIGHT ANGLE SOLDER HEADER	
				dr	.XXX±.0020/0.XXX±0.051			product family PwrBlade code 213	
				enr	D. INGRAM 02/10/04	scale		size 51730-089 sheet 3 of 4	
				chr	M. GRAY 02/10/04	1:1			
				appd	M. GRAY 02/10/04				
sheet index	revision sheet								

cage code 22526

Pro/E

PDM: Rev:C

STATUS: Released

Printed: Aug 12, 2007

Tous droits strictement réservés. Reproduction ou communication à des tiers interdite sous quelque forme que ce soit sans autorisation écrite du propriétaire. Propriété de c FCI. Droits de reproduction FCI.

**A**  
**FCI**

All rights strictly reserved. Reproduction or issue to third parties in any form whatever is not permitted without written authority from the proprietor. Property of FCI. Copyright FCI.

**B**

PRODUCT NUMBER  
51730-089\_-  
NOTE: ③

NOTES:

1. DIMENSIONS AND TOLERANCES ARE IN ACCORDANCE WITH ASME Y14.5M, 1994 UNLESS OTHERWISE SPECIFIED.

2. CONNECTOR NOTES:

HOUSING MATERIAL: UL 94 V-0 GLASS FILLED HIGH-TEMP THERMOPLASTIC  
POWER CONTACT MATERIAL: COPPER ALLOY  
SIGNAL PIN MATERIAL: COPPER ALLOY

3. PLATING:

51730-089 Singal Pin:30u"/0.76um Au OVER 50u"/1.27um Ni ON THE CONTACT AREA.  
AND 100u"/2.54um SnPb PLATING OVER 50u"/1.27um Ni ON THE TERMINATION SECTION.  
Power Pin:30u"/0.76um Au OVER 50u"/1.27um Ni ON THE CONTACT AREA,  
AND 100u"/2.54um SnPb PLATING OVER 50u"/1.27um Ni ON THE TERMINATION SECTION.

51730-089LF Singal Pin:30u"/0.76um Au OVER 50u"/1.27um Ni ON THE CONTACT AREA.  
AND 78u"/2.00um Sn PLATING OVER 50u"/1.27um Ni ON THE TERMINATION SECTION.  
Power Pin:30u"/0.76um Au OVER 50u"/1.27um Ni ON THE CONTACT AREA,  
AND 78u"/2.00um Sn PLATING OVER 50u"/1.27um Ni ON THE TERMINATION SECTION.

PART NUMBER 51730-089LF MEETS EUROPEAN UNION DIRECTIVE AND OTHER COUNTRY REGULATIONS AS DESCRIBED IN GS-22-008.

THE HOUSING WILL WITHSTAND EXPOSURE TO 260° PEAK TEMPERATURE FOR 10 SECONDS IN A WAVE SOLDER APPLICATION WITH A CIRCUIT BOARD.

4. MANUFACTURER'S NAME, P/N, AND DATE CODE TO APPEAR ON THIS SURFACE.

5. PRODUCT SPECIFICATION GS-12-149.  
APPLICATION SPECIFICATION BUS-20-067.

6. PACKAGED IN TRAYS.

PCB NOTES:

7. ALL HOLE DIAMETERS ARE FINISHED HOLE SIZE.

8. MOUNTING HOLES, WHERE APPLICABLE, ARE UNPLATED.

9.  $\varnothing .0453 \pm .0010$  [1.151 ± 0.025] DRILLED HOLES PLATED WITH .0003 [0.008] MIN SnPb OVER .001 [0.03] TO .003 [0.08] Cu PLATING TO ACHIEVE  $\varnothing .040 \pm .003$  [1.02 ± .07] HOLE.

10. "DIM XXX" TO BE DETERMINED BY THE CUSTOMER.

11. CONNECTOR KEEP-OUT ZONE.

mat'l code				SEE NOTE 2		tolerances unless otherwise specified		CUSTOMER		<b>A</b> <b>FCI</b> www.fciconnect.com	
ltr	ecr no.	dr	date	linear	.XX±.01/0.X±0.3	COPY		projection		title 4P + 40S + 4P	
C					.XXX±.005/0.XX±0.13					RIGHT ANGLE SOLDER HEADER	
				angles	XXXX±.0020/0.XXX±0.051					product family PwrBlade	
				dr	0° ± 2°	D. INGRAM 02/10/04		size		code 213	
				enr		M. GRAY 02/10/04		A		sheet 4 of 4	
				chr		M. GRAY 02/10/04		51730-089			
				appd		M. GRAY 02/10/04		scale 1:1			
sheet index	revision sheet										

cage code 22526 4

**PDM: Rev:C**

**STATUS: Released**

Printed: Aug 12, 2007